

# Unpacking the realities of behaviour change interventions at scale

## Case study: Latrine construction – Mozambique

**B. Gopalan<sup>1</sup>, N. Desai<sup>1</sup>, A. Biran<sup>2</sup>, G.Halcrow<sup>3</sup>, T.Dem<sup>3</sup>, S.Niska<sup>3</sup>, Z.Salvador<sup>3</sup>, R.Sanderson<sup>4</sup>, C.Lifoia<sup>5</sup>**

<sup>1</sup>Upward Spiral

<sup>2</sup>LSHTM

<sup>3</sup>SNV

<sup>4</sup>International Water Centre at Griffith University

<sup>5</sup>Solomon Islands National University

India, UK, Bhutan, Australia, Solomon Islands, Mozambique, Indonesia



LONDON  
SCHOOL of  
HYGIENE  
& TROPICAL  
MEDICINE



SNV



Griffith  
UNIVERSITY  
Queensland, Australia



WATER  
&  
WASH 2023  
FUTURES

Achieving SDG6 in a Changing Climate



#WaWF23

# The Programme Context



**PRONASAR**  
Programa Nacional de Abastecimento  
de Água e Saneamento Rural

National Rural Water Supply  
and Sanitation Programme

Goal: 100% ODF in 2025



48% Basic  
Latrine

42% OD





# Target behaviour

Construction of Durable latrines (those who can withstand heavy rains and termites) in rural communities.





# Process

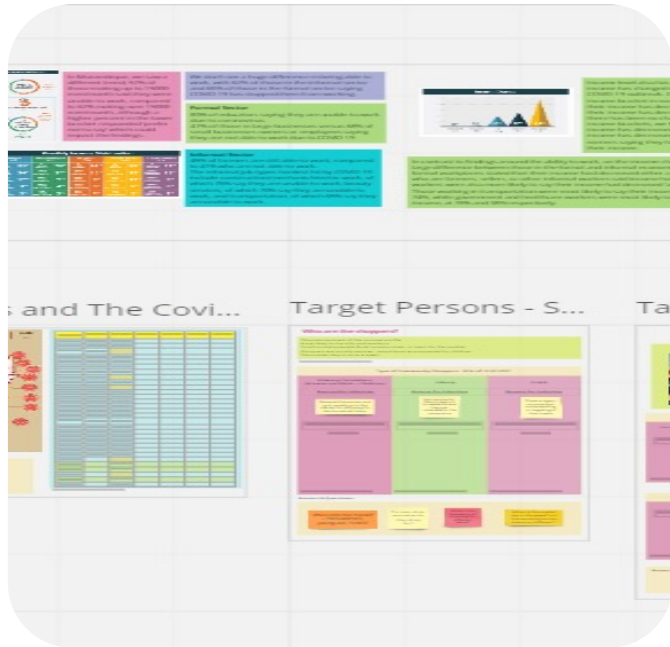

## Assess

- Existing Knowledge
- Identification of key - research questions

## Formative Research



- Training of Research Team: Gov + SNV
- Field Research: KII, FDG, Observation
- Report



# Process

## NAMIRUKU Campaign

### Creative Design

- Intervention Ideas
- Pre-Test
- Intervention
- Concept
- Materials (Videos, Audio Spots, IEC Materials, Jingle, etc)





# Process

## Delivery

- Launch of Namiruku campaign
- Implementation team training
- Mobilization Activities
- Monitoring
- Namiruku Celebration





# Process

## Evaluation

- Baseline and Endline (LogAlto)
- Qualitative Survey (KII, FDG, Observation): Delivery team Government and Communities;

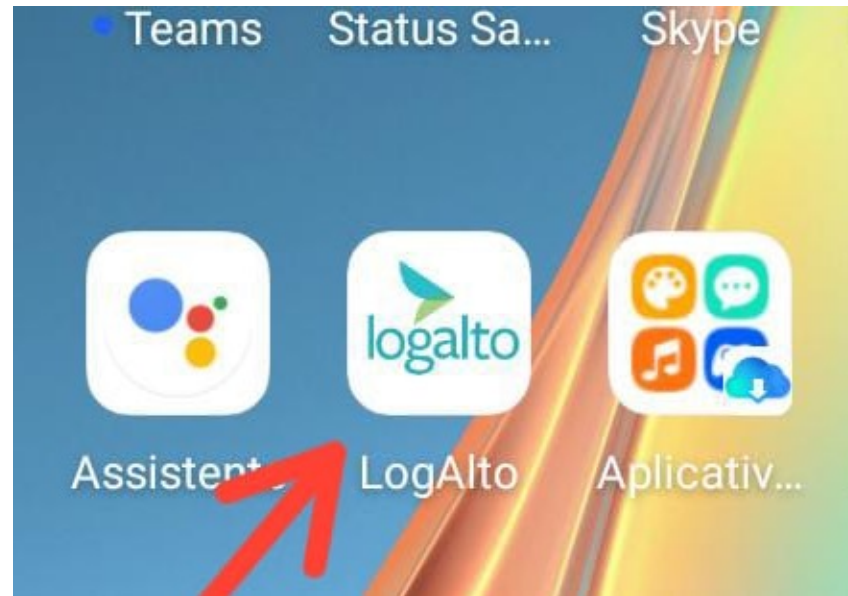

← Levantamento de base para camp...

LOCALIZAÇÃO E DADOS BASICOS DA COM... ▾

Chapala

---

Comunidades\_Chapala \*

Chapala Sede

---

Coordenada\_Comunidade\_Alto\_Molocue\_sede \*

-17.8707485      36.8978306      📍

---

Coordenada\_Comunidades\_Nauela \*

-17.8689751      36.8944695      📍

---

Coordenadas geograficas da comunidade \*

-17.8689751      36.8944695      📍

---

Nome do avaliador

Chandinho Vontade

---

< PREVIOUS      ● ● ● ● ●      NEXT >

## Insight 1

Basic latrines collapse frequently due to heavy rains and termites. Therefore, people need to be rebuilt frequently.

If they build a durable latrine, can forget about it and get on with their life.

Intervention idea:

**Saves Time and Effort**





## Insight 2

Building a durable latrine enhances one's status in the community.

Namiruku - someone with a durable latrine is more aspirational – smart/wise, Educated, Richer, Intelligent, Open-minded etc.'

**Better Status**



Intervention idea:





## Intervention idea:

### Cost and Effort

### Insight 3

The cost and effort required to build a durable latrine is a barrier to its construction.

Knowledge about low-cost latrine that could be made by local material with personal labor was shared.





## Intervention idea:

### 5-Star Latrine of Namiruku

#### Insight 4

A specific durable latrine option has not been defined. Aspects must be considered during the construction to ensure durability.

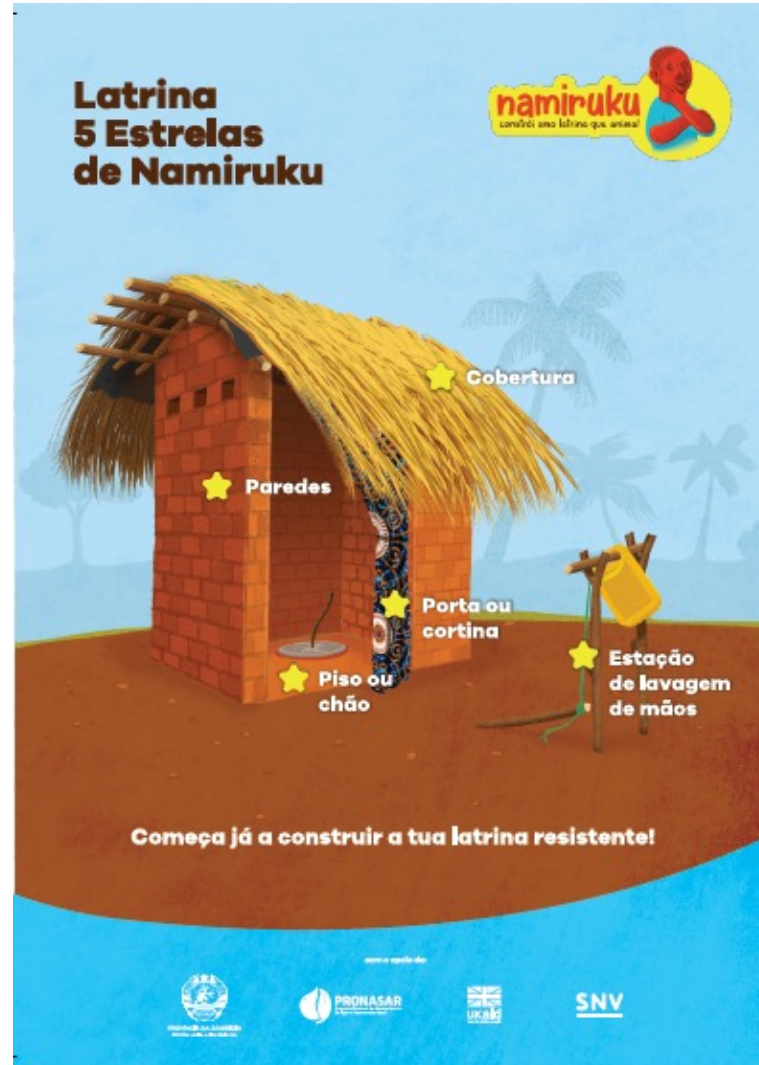

Partes da latrina	Descrição	Estrelas
Piso ou chão	<ul style="list-style-type: none"><li>• Piso feito com paus fortes e maticado com argila, ou feito com laje de cimento</li><li>• Tampa no buraco da latrina</li></ul>	★
Paredes	<ul style="list-style-type: none"><li>• Blocos de adobe ou tijolos queimados</li><li>• Espaço entre a parede e o telhado ou buracos nas paredes para ventilação</li></ul>	★
Cobertura	<ul style="list-style-type: none"><li>• Feita com paus e capim (se tiver plástico melhor) ou feita com chapas de zinco</li><li>• O tecto deve se estender além da parede</li></ul>	★
Porta ou cortina	<ul style="list-style-type: none"><li>• A porta ou cortina pode ser feita com madeira, tecido, paus, chapas de zinco, etc.</li></ul>	★
Estação de lavagem de mãos	<ul style="list-style-type: none"><li>• Tambor ou balde de água + caneca ou Tippy tapy</li><li>• Recipientes para sabão</li></ul>	★
Inclusão	<ul style="list-style-type: none"><li>• Adaptações para pessoas com deficiência: corrimão, cadeira, rampa, sinalizadores para localizar a casa de banho, o buraco e a água, etc.</li></ul>	+



# Intervention Design - Summary

## Roadshows



## Training Workshops



## Follow - up





# Intervention Delivery – Geography



Zambezia Province: Ile and Alto Molocue Districts. 44 Communities in Total.



# Outcomes

## Latrine Construction

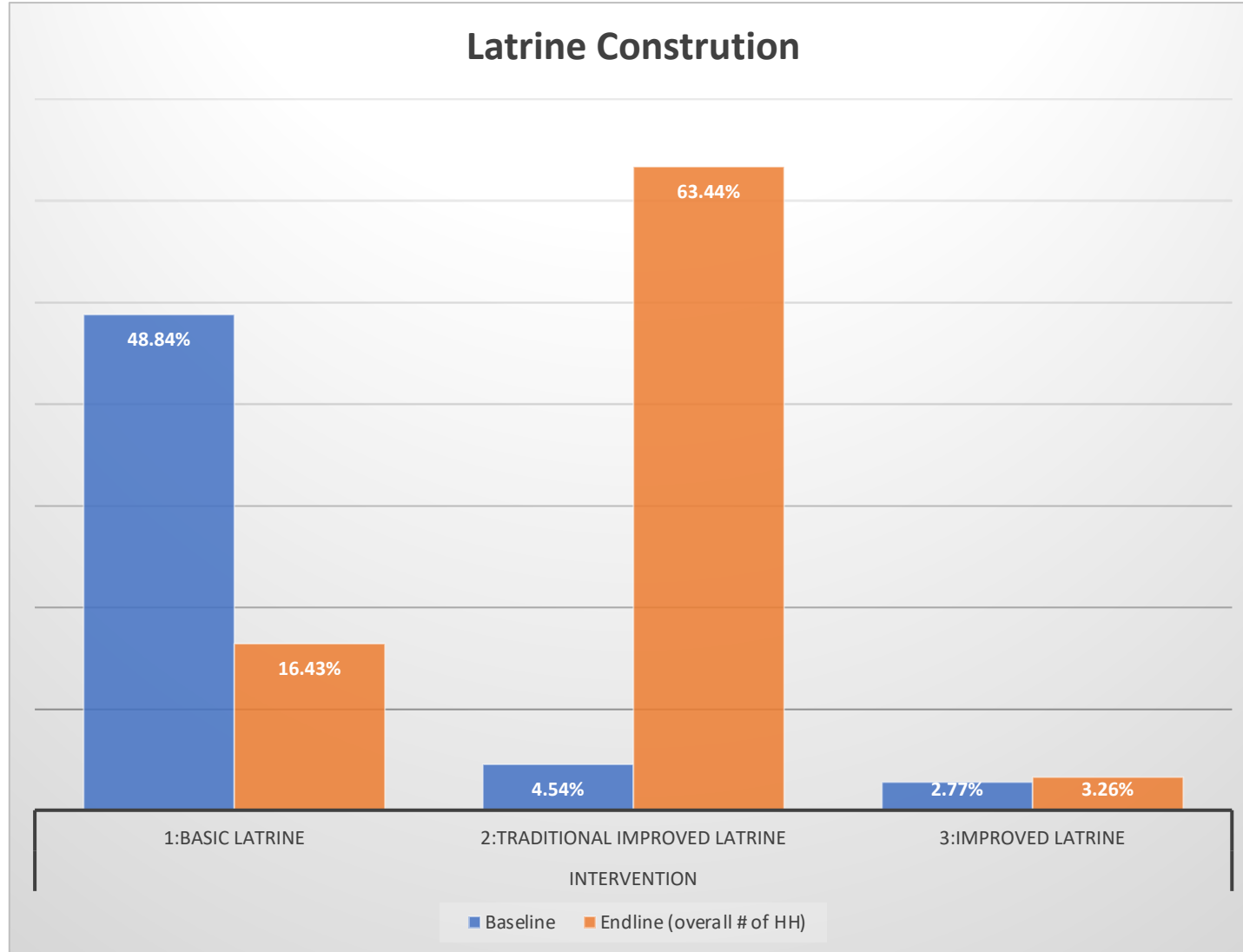

Note: Evaluation data under review



# Scale up

- Conduat a study on latrine construction in coastal areas;
- Government capacity building on BCD framework;
- Promote the Namiruku campaign nationally among Government stakeholders and other NGOs.

## Latrines for coastal areas

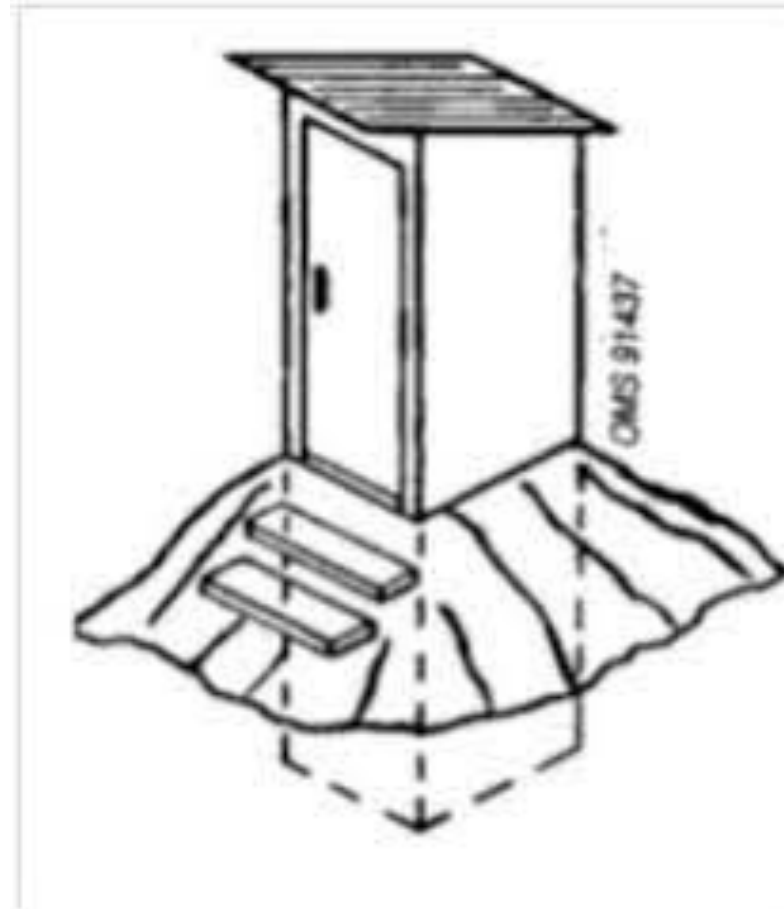

# Challenges faced

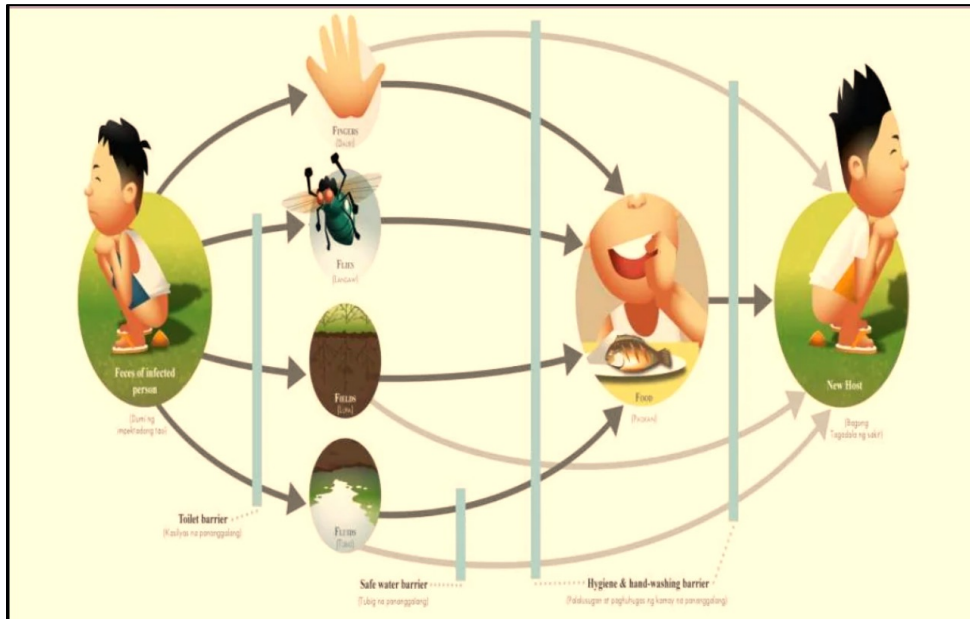

Connect the Hub facilitators to local partners: Government, Creative team and implementation team

Avoid health messages on the intervention

Hard to monitor activities due to the distance between villages and households

Short period for the intervention to meet the goals

Availability of the household to build its latrine due to priority for harvest season in the farm



# Learnings

Parameter	What worked well?	What can be improved?
Design effective interventions	Formative Research	Monitoring and Evaluation skills for the team.
Facilitate Scale-up	Share the intervention process for partners incl. Government.	Engagement of Government in all process;
Efficient use resources	Joint discussion sessions between teams during the process	Engagement of more actors
Strengthen capacities	Learning by doing approach	
Improve program sustainability	Community engagement;	Engagement of other partners such as the private sector.

[bala@upwardspiral.in](mailto:bala@upwardspiral.in) | [nipa@upwardspiral.in](mailto:nipa@upwardspiral.in)

[adam.biran@lshtm.ac.uk](mailto:adam.biran@lshtm.ac.uk)

[ghalcrow@snv.org](mailto:ghalcrow@snv.org) | [tdem@snv.org](mailto:tdem@snv.org) | [sniska@snv.org](mailto:sniska@snv.org) |  
[zsalvador@snv.org](mailto:zsalvador@snv.org)

[r.sanderson@griffith.edu.au](mailto:r.sanderson@griffith.edu.au) | [r.souter@griffith.edu.au](mailto:r.souter@griffith.edu.au)

[clement.lifoia@sinu.edu.sb](mailto:clement.lifoia@sinu.edu.sb)

**WATER**  
**WASH** 2023  
FUTURES

Achieving SDG6 in a Changing Climate